



MAKES IT HAPPEN

► Motorcycle, vehicle and universal

Transportation Trailer

from 750 kg up to 3.5 t



HUMBAUR
TRAILERS UP TO 3,5t



4000 Series

humbaur.com



Table of contents

Experience it for yourself	4
At home on the road	6
Motorcycle transporters/small vehicle transporters	
HM motorcycle transporters.....	10
Motorcycle/small vehicle transporters KFT	14
Vehicle transporters	
Tilting FTK	18
Lowering HKT	22
Universal high-loader car transporters	26
Vehicle transporters HAK	30
MTK tilting high-loader	34
Universal transporters	
MTK tilting all-comfort high-loader	38
Senko lowering trailer	42
REXUS all-poly trailer	46
Optional accessories.....	50
About Humbaur	55



Experience it for yourself



Our rationale makes it easy for you to become a staunch supporter of Humbaur's high-quality products.

30 years of experience

We have been one of the leading manufacturers of passenger vehicle trailers for three decades. Over 850,000 trailers have left our premises since our company was founded. Nowadays, we produce around 52,000 units per year. And our wealth of experience is reflected in each of our trailers.

High quality

Robust and long-lasting – that's what a trailer needs to be. We use outstanding components and first-rate processing to achieve this goal. Before we deliver each trailer, we put it through its paces.

A wide range of transportation solutions

Our offering covers a very wide range of applications: Private and commercial customers can find a suitable trailer for a wide range of uses. You can choose between a total permissible weight from 750 kg up to 50 t.



MAKES IT HAPPEN

Wide range of accessories

Some of our customers place very specific demands on their trailers. Thanks to a number of matching accessories, you can add to the comprehensive standard features to meet your requirements accordingly.

Committed customer service

If your trailer weighs up to 3.5 t, your specialist dealer in your area will be happy to help. Owners of trailers weighing upwards of 5 t total weight are able to take advantage of our direct service. Whether you need a spare part or have a question about how to use your trailer – we, together with your on-site dealer, will be happy to help.

High-quality components

Quality is reflected in the detail – that's why Humbaur only uses high-quality vehicle components that have been produced by reputable manufacturers. We continuously share our experiences with our suppliers. In this way we are able to continuously improve our products.

I'm a true follower!

Because HUMBAUR is master of transportation.

Konrad König, Automobile Technician, Stuttgart



At home on the road

The 4000 Series



**Motorcycle transporter
HM**

The HM motorcycle transporter for up to three motorcycles gets you safely to your destination, whether you are off to the track, to the workshop or on holiday. You can securely fasten your motorcycles to 10 galvanised load-securing eyes. A loading ramp is stored in a plank shaft under the trailer; it can be assembled in just a few steps. Optional prop stands are available as accessories for all models, as are wheel shock absorbers and a plastic tool box. Your motorcycle trailer can therefore be equipped to meet your every need.



KFT small vehicle transporter

The KFT small vehicle and motorcycle transporter is available with two equipment packages that provide for either vehicle or motorcycle transportation. The "vehicle transportation" package includes the mounted plank shaft and two aluminium ramps, along with two prop stands. The "motorcycle transportation" package includes the mounted plank shaft, two loose motorcycle stands, two loose connection brackets and a motorcycle loading ramp. A stand and connection bracket for a third motorcycle are available as an additional option. The aluminium sides are equipped with integrated tie-down hoops. When fitted with the optional 350-mm aluminium side, the Humbaar KFT becomes truly multifunctional,



**Vehicle transporter
FTK**

**Available in single/
tandem axle!**

Use the new tilting FTK vehicle transporter from Humbaar to transport your vehicle comfortably and safely. The FTK also offers the benefits of tilting vehicle trailers for compact vehicles. Ideal for companies who carry out vehicle repairs or for private users wishing to transport small vehicles such as a Smart or VW Golf. You can use shock absorbers to mechanically tilt the bridge and effortlessly load your vehicle on to the trailer via serrated steel loading ramps. Available with a cable winch and tilting hydraulic mechanism (both optional).



Small vehicle transporter HKT

The multi-functional versatile Humbaur HKT makes it easier for you than ever to transport small vehicles. All HKT trailer models are fitted as standard with a bolted and hot-dip galvanised chassis. The hydraulically lowering loading area allows you to load and unload the trailer comfortably and conveniently at a very low ramp angle. One of the features of the new single-axis HKT lowering trailer is the ramp front edge at the rear. Standard equipment also includes slots in each corner.



Universal vehicle transporter

The solid base plate, placed on the transporter's hot-dip galvanised chassis and frame, can be used for almost all transportation options. The vehicle can be loaded onto the universal trailer by means of two corrosion-resistant drive-up ramps. The entire width of the ramps can be adjusted, meaning they can be precisely adapted to the track width of the vehicle. The ramps can then be slid under the loading area. The load can be secured to seven load-securing rings for safe transportation. An aluminium instead of wooden floor, aluminium side panels, and tarpaulin with frame can be retrofitted at any time.



Vehicle transporter HAK

The HAK vehicle transporter series, thanks to an interior width of 2,005 mm, can transport a variety of vehicles. The tilting bridge, which can be mechanically tilted using shock absorbers, provides for a flat ramp angle so that cars and other vehicles can be loaded easily. The depth-adjustable cable winch frame with cable winch and traction cable provides support when loading. Load-securing options are provided by the side perforations and on the stand rails so that the vehicles being transported can be secured. The durability of the HAK vehicle transporter is not only down to its robust design, but also its hot-dip galvanised chassis, frame, and square tow bar.

At home on the road

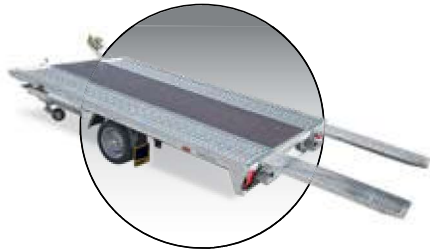

Available in single/
tandem axle!

Vehicle transporter MTK

Its extremely robust and durable design makes the MTK, available in single/tandem axles, the ideal trailer for anyone wishing to transport professional vehicles. With a total permissible weight of between 1,500 and 3,500 kg, it can also be used to transport heavier passenger vehicles. The frame and chassis are hot-dip galvanised. The cable winch, which can be adjusted lengthways, is mounted on a robust frame. The vehicle can be driven over extendible, hot-dip galvanised steel ramps at a slight angle on to the trailer. An optional hydraulic mechanism lifts the bridge for this purpose. Load-securing options, each with 400 kg of tensile force, are positioned in the side of the outer frame to secure the load.



Available in single/
tandem axle!

Universal transporter MTK Allcomfort

Makes every application as easy as possible for you: Simply use a manual pump to tilt the hydraulic bridge. Pneumatic springs will help you to operate the ramp gate. Thanks to the low loading height of 640 mm (single axle) or 650 mm (tandem axle), the ramp angle remains very flat. This means you can easily load machinery and vehicles that are in a lower lying position. A robust, optional cable winch frame with cable winch is provided on the trailer to help you load effortlessly. The sophisticated chassis technology of the MTK Allcomfort provides for an extremely quiet ride.



Lowering trailer Senko

The Senko goes out of its way to help and can also accommodate vehicles with low ground clearance. The loading area can also be hydraulically lowered easily by means of a manual pump or you also have the option of lowering it electronically, making life even easier. Its retractable rubber spring axles give you an almost level loading angle. This makes the Senko extremely robust. The 3 mm-thick steel plate side panels can withstand large loads. Each of the ten load-securing rings has been tested by DEKRA to a tensile load of 800 kg. Of course, all vehicle components are hot-dip galvanised.



All-poly container trailer Rexus

Transport your goods to their final destination in style: The Rexus has the appearance of a horse trailer thanks to its retro aesthetics. This is also evident in the tried-and-tested chassis frame side member. Design lighting with chrome rings, an interior light and ready-fitted side and clearance lights, as well as the side entry door, refine its special design. The reardoor is coated inside with aluminium chequer plate and can carry up to 1,285 kg, as confirmed by DEKRA. What would you like to transport? Take a look at the accessories list, the Rexus provides you with a lot of options.





The new motorcycle transporter **HM**



Ready to transport three stylish motorcycles

- 1** Hot-dip galvanised square tow bar
- 2** 13-pin plug and reversing light
- 3** 10 galvanised load-securing eyes for securing the load
- 4** 3 stand rails with loops, fitted
- 5** Loading ramp built into the plank shaft
- 6** Humbaur multifunctional lighting



4000 Series

Model	HM 752113
Overall dimension in mm	3,142 x 1,765 x 980
Internal dimension in mm	2,095 x 1,365 x 70
Total permissible weight in kg	750
Load capacity in kg	575
Load height in mm	515
Tyres in inches	13
Ramp angle	15°

Model	HM 102113
Overall dimension in mm	3,195 x 1,765 x 990
Internal dimension in mm	2,095 x 1,365 x 70
Total permissible weight in kg	1,000
Load capacity in kg	789
Load height in mm	535
Tyres in inches	13
Ramp angle	15°

- 1 1 loading ramp built into the plank shaft
- 2 3 stand rails with loops, fitted
- 3 Large-size quality tyres for a quiet ride, even on poor road surfaces

Subject to change without notice. All dimensions are approximate values and refer to the standard vehicle without accessories.



1



2



1

The new motorcycle transporter **HM**



*Accessories (optional):

- 2 x prop stands
- Jockey wheel
- Spare wheel
- Loose wheel shock absorbers
- Fitted wheel shock absorbers
- 7-13-pin adapter
- Plug lock
- unbraked trailers
- Toolbox





Small vehicle transporter **KFT**

Designed to transport small vehicles or up to three motorcycles

- 1** Hot-dip galvanised square tow bar
- 2** 13-pin plug
- 3** Base plate 15 mm
- 4** 10 load securing options in the aluminium side plate
- 5** Fully automatic jockey wheel
- 6** Vehicle transport or motorcycle transport accessory kit (available as an option)
- 7** Humbaur multifunctional lighting with reversing lights
- 8** Wheel shock absorbers (optional accessory)

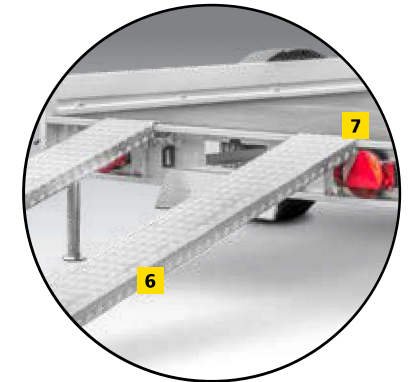
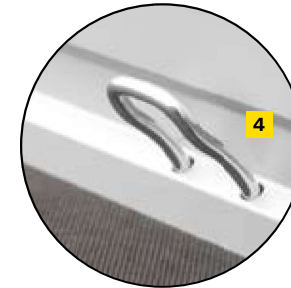

4000 Series

Model	KFT 153117 aluminium
Overall dimension in mm	4445 x 2260 x 930
Internal dimension in mm	3115 x 1765 x 150
Total permissible weight in kg	1,500
Load capacity in kg	1196
Load height in mm	570
Tyres in inches	14

1 + 2 Vehicle transporter accessory kit includes:

- Plank shaft
- 2x Aluminium ramps
- 2x Prop stands (mounted)

3 + 4 Motorcycle transporter accessory kit includes:

- Plank shaft
- 2x Motorcycle stands (loose)
- 2x Connection brackets (loose)
- 1x Motorcycle loading ramp

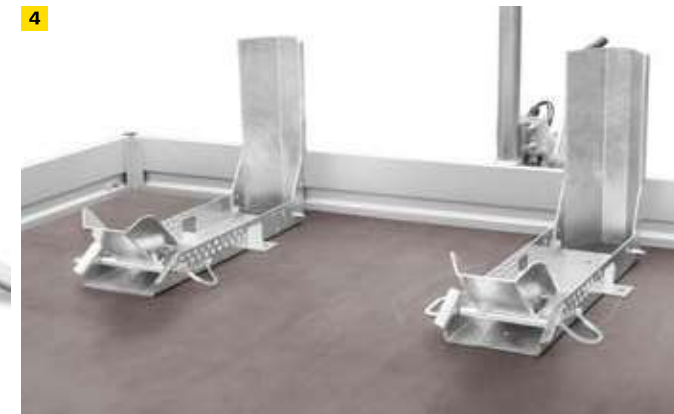

Subject to change without notice. All dimensions are approximate values and refer to the standard vehicle without accessories.

Small vehicle transporter KFT

*Accessories (optional):

- 2 x prop stands
- Spare wheel
- Loose wheel shock absorbers
- Fitted wheel shock absorbers
- Side plate height 350 mm
- Vehicle transporter package
- Motorcycle transporter package

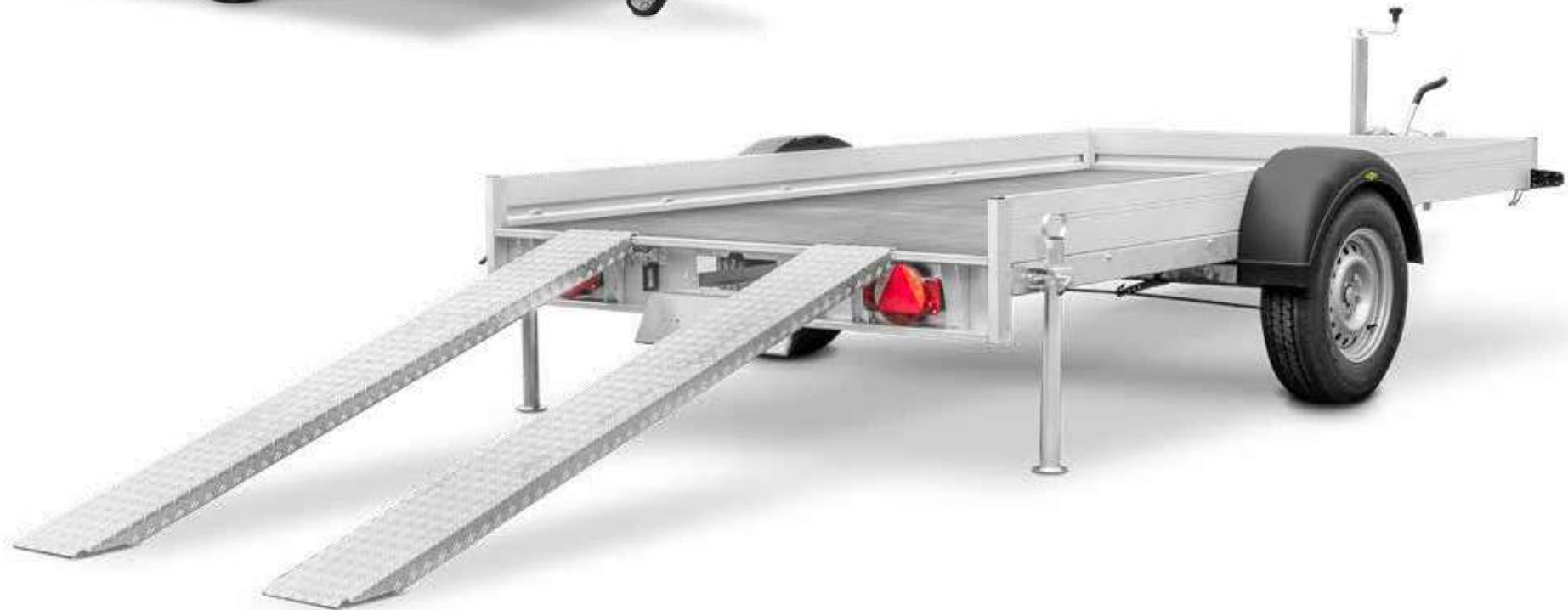



Small vehicle transporter FTK

Robust, flexible and
a great transporter

- 1 Bolted and galvanised chassis
- 2 Galvanised tilting bridge
- 3 Tilting bridge mechanically tilted using shock absorbers.
- 4 Hot-dip galvanised steel loading ramps
- 5 Hot-dip galvanised square tow bar
- 6 13-pin plug
- 7 Jockey wheel
- 8 Optional cable winch frame with cable winch
- 9 Optional wheel stop can be adjusted on the stand rails
- 10 Humbaur multifunctional lighting with reversing lights

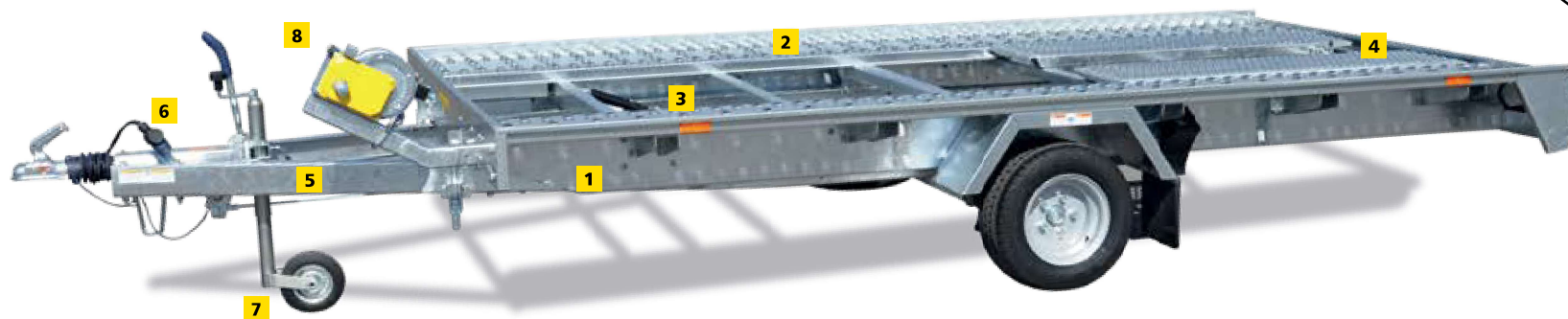
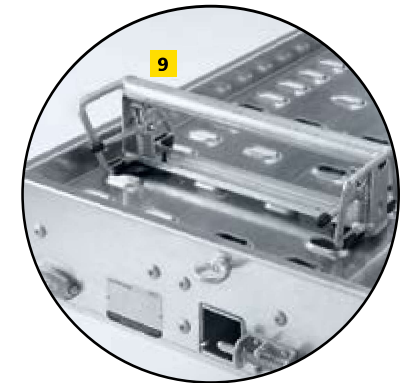
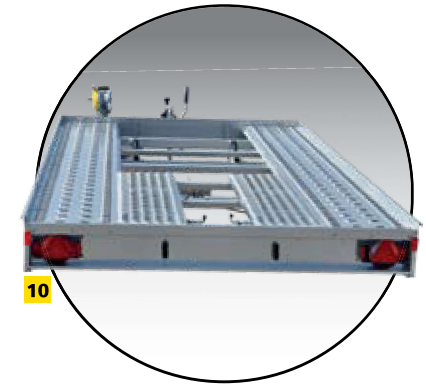
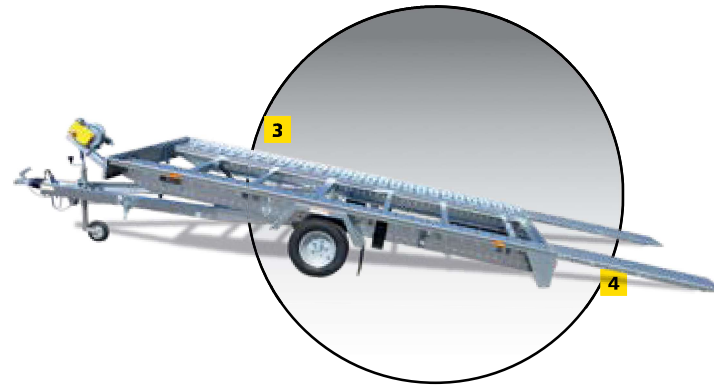

4000 Series

Model	FTK 133520	FTK 153520
Overall dimension in mm	4,880 x 2,050 x 630	4,880 x 2,050 x 630
Internal dimension in mm	3,500 x 2,000 x 50	3,500 x 2,000 x 50
Total permissible weight in kg	1,300	1,500
Load capacity in kg	860	1,060
Load height in mm	580	580
Tyres in inches	10	10
Ramp angle	10°	10°

Model	FTK 204020	FTK 274020
Overall dimension in mm	5,375 x 2,050 x 630	5,375 x 2,050 x 630
Internal dimension in mm	4,000 x 2,000 x 50	4,000 x 2,000 x 50
Total permissible weight in kg	2,000	2,700
Load capacity in kg	1,370	2,070
Load height in mm	580	580
Tyres in inches	10	10
Ramp angle	9°	9°

- 1 Optional wheel stop for securing the load
- 2 Shock absorbers for the mechanical tilting function
- 3 + 4 Easy handling for fitting the steel loading ramps

Subject to change without notice. All dimensions are approximate values and refer to the standard vehicle without accessories.

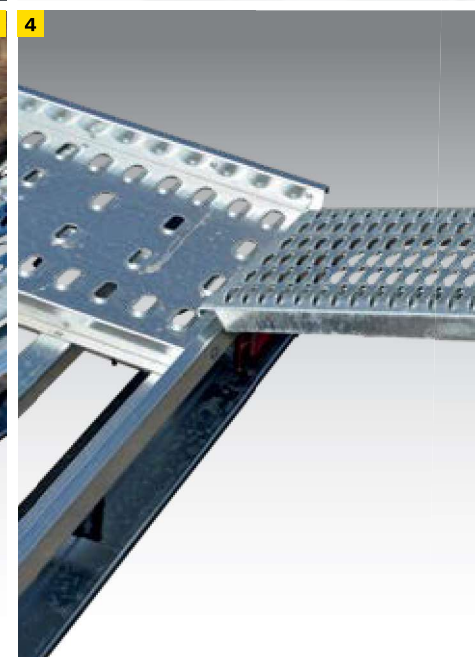
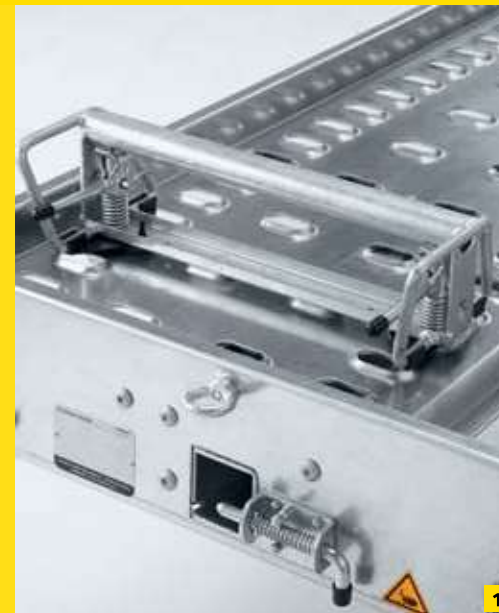

Small vehicle transporter FTK



Accessories (optional):

- Cable winch frame with cable winch
- Wheel stop 360 mm
- Spare wheel bracket for the FTK, loose
- Spare wheel
- Loose wheel shock absorbers
- Fitted wheel shock absorbers
- 7-13-pin adapter
- Passenger vehicle lashing strap, 50 mm belt width, length 2,500 mm
- Automatic jockey wheel
- Hydraulic system with double-acting cylinder to tilt the loading area
- Spare wheel with bracket



Vehicle transporter HKT

Designed for transporting motorcycles or small vehicles

- 1 Bolted, **galvanised chassis frame**
- 2 Loading area **can be lowered hydraulically**
- 3 **Mechanical safety lock** on the swivel axis in driving mode
- 4 Humbaur **multifunctional lighting** with **reversing lights**
- 5 With **ramp front edge at the rear**
- 6 **Number plate holder** at the rear, can be swivelled out **when loading**
- 7 **Wooden floor** 15 mm thick
- 8 **Aluminium side panels** 150 mm-high with **built-in load-securing rings** (tensile force 400 kg per load-securing ring, tested by Dekra)
- 9 **Slots** in each corner for tarpaulin frame, for example
- 10 **13-pin plug**
- 11 **Manual pump** to **raise and lower** the **loading area**

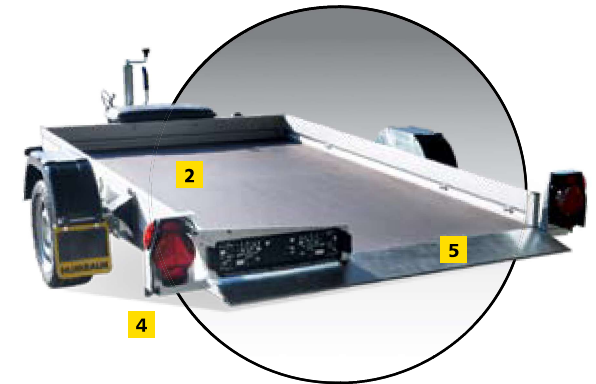

4000 Series

Model	HKT 752515 S	HKT 132515 S	HKT 152515 S	HKT 182515 S
Overall dimension in mm	4,050 x 2,250 x 660	4,085 x 2,250 x 660	4,085 x 2,250 x 660	4,085 x 2,250 x 660
Internal dimension in mm	2,500 x 1,565 x 150	2,500 x 1,565 x 150	2,500 x 1,565 x 150	2,500 x 1,565 x 150
Total permissible weight in kg	750	1,350	1,500	1,800
Load capacity in kg	450	1,018	1,168	1,450
Load height in mm	420	420	420	420
Tyres in inches	13	13	13	13
Ramp angle	6°	6°	6°	6°

Model	HKT 132817 S	HKT 152817 S	HKT 182817 S	HKT 133117 S
Overall dimension in mm	4,410 x 2,450 x 670	4,410 x 2,450 x 670	4,410 x 2,450 x 670	4,610 x 2,450 x 670
Internal dimension in mm	2,800 x 1,765 x 150	2,800 x 1,765 x 150	2,800 x 1,765 x 150	3,100 x 1,765 x 150
Total permissible weight in kg	1,350	1,500	1,800	1,350
Load capacity in kg	1,000	1,150	1,410	985
Load height in mm	420	420	420	420
Tyres in inches	13	13	13	13
Ramp angle	5°	5°	5°	4°

Model	HKT 153117 S	HKT 183117 S
Overall dimension in mm	4,610 x 2,450 x 670	4,610 x 2,450 x 670
Internal dimension in mm	3,100 x 1,765 x 150	3,100 x 1,765 x 150
Total permissible weight in kg	1,500	1,800
Load capacity in kg	1,135	1,415
Load height in mm	420	420
Tyres in inches	13	13
Ramp angle	4°	4°

- 1 Optional motorcycle stand
- 2 Manual pump with oil reservoir
- 3 Aluminium floor also available instead of wooden floor

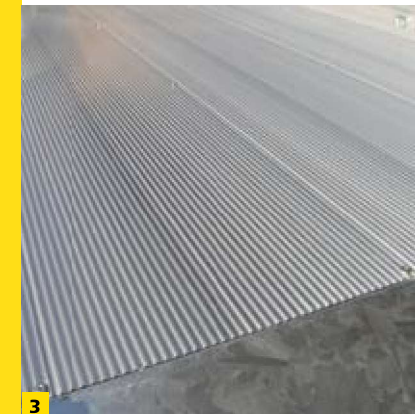

Subject to change without notice. All dimensions are approximate values and refer to the standard vehicle without accessories.

Vehicle transporter HKT



...optional motorcycle stand
for mounting on the loading area*

*Accessories (optional):

- Loose wheel shock absorbers
- Fitted wheel shock absorbers
- Tarpaulin & frame, grey or blue, load height 1,600 mm/1,800 mm,
- Tarpaulin & frame, blue, load height 1,600 mm/1,800 mm, for optional gate
- Motorcycle carrier
- Spare wheel
- 7/13-pin adapter
- Plug lock for unbraked trailers
- 350 mm side panels
- Tailgate instead of ramp front edge
- Toolbox on tow bar



4/5/6°
depending on the
model



High-loader **Universal**

Universally applicable – in the truest sense of the word

- 1** Screwed-in square tow bar, hot-dip galvanised
- 2** 13-pin plug
- 3** Base plate 18 mm thick
- 4** 2 hot-dip galvanised drive-up ramps, grated inserted under the loading area
- 5** 2 supporting feet (Universal 3500)
- 6** 7 load-securing rings on each side in the outer frame profile
- 7** Perforations for wheel stop in the outer frame profile
- 8** Cable winch with cable and 3-way depth-adjustable bracket
- 9** Automatic jockey wheel (Universal 3000)
- 10** Jockey wheel with large wheel spool (Universal 3500)
- 11** Humbaur multifunctional lighting with reversing lights

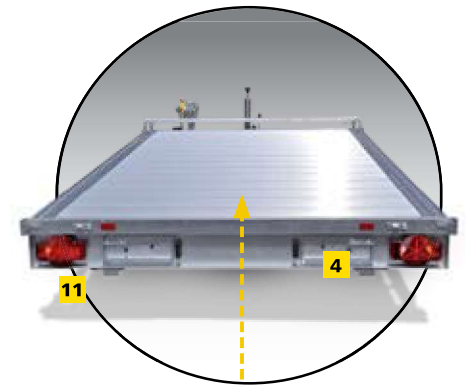

...with optional aluminium floor*

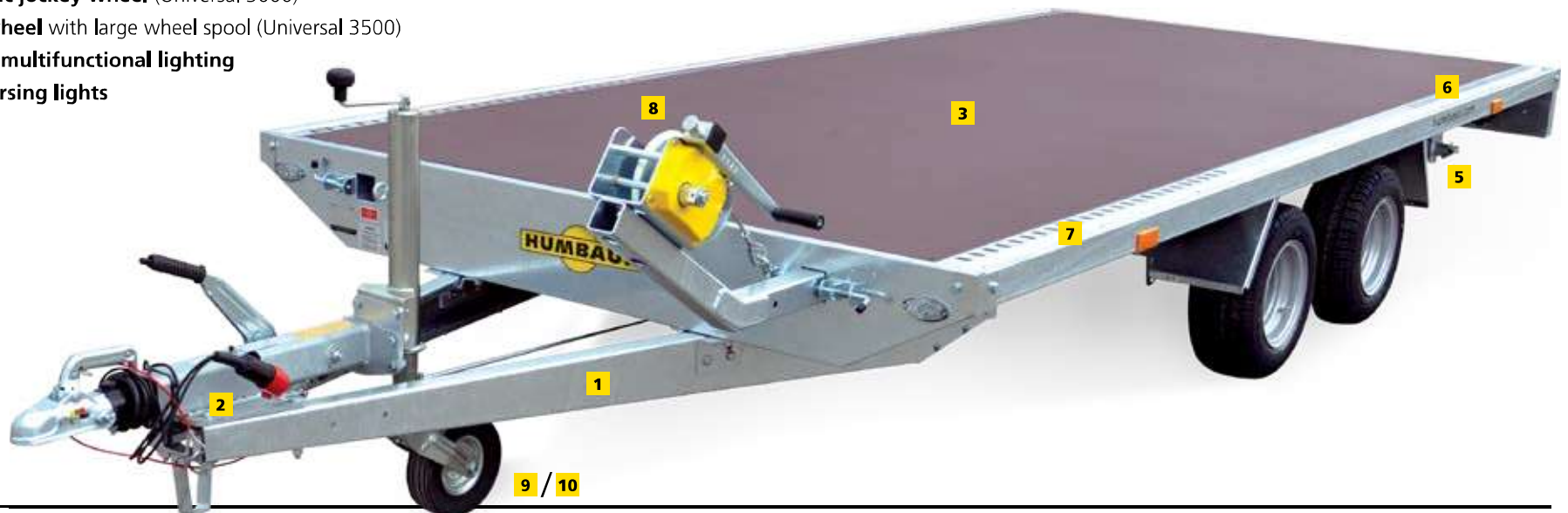

4000 Series

Wooden floor

Universal 3000

Overall dimension in mm	5,374 x 2,034 x 830
Internal dimension in mm	4,000 x 2,030
Total permissible weight in kg	3,000
Load capacity in kg	2,310
Load height in mm	600
Tyres in inches	10
Ramp angle	13°

Universal 3500

Overall dimension in mm	5,405 x 2,050 x 890
Internal dimension in mm	4,000 x 2,030
Total permissible weight in kg	3,500
Load capacity in kg	2,714
Load height in mm	670
Tyres in inches	13
Ramp angle	15°

Aluminium floor

Universal 3000

Overall dimension in mm	5,374 x 2,034 x 830
Internal dimension in mm	4,000 x 2,030
Total permissible weight in kg	3,000
Load capacity in kg	2,320
Load height in mm	600
Tyres in inches	10
Ramp angle	13°

Universal 3500

Overall dimension in mm	5,405 x 2,050 x 890
Internal dimension in mm	4,000 x 2,030
Total permissible weight in kg	3,500
Load capacity in kg	2,743
Load height in mm	670
Tyres in inches	13
Ramp angle	15°



1



2



3



4

- 1 Robust base frame made up of angled steel profiles
- 2 Adjustment settings on the optional wheel stop
- 3 Hot-dip galvanised steel drive-up ramps
- 4 Cable winch with cable and 3-way adjustable bracket

Subject to change without notice. All dimensions are approximate values and refer to the standard vehicle without accessories.

High-loader Universal



...Tarpaulin structure available as an option*



...Side panels available as an option*

*Accessories (optional):

- Spare wheel
- Spare wheel bracket
- Spare wheel bracket under the loading area
- Loose wheel shock absorbers
- Fitted wheel shock absorbers
- Universal wheel stop
- 800 mm-high H-frame
- 350 mm side panel extension
- 350 mm side panels
- Passenger vehicle lashing strap, 50 mm belt width/2,500 mm
- Tarpaulin & frame, load height 1,800 mm/2,000 mm; free to choose colour
- Supporting feet
- Toolbox





Vehicle transporter **HAK**

Wide, flat, comfortable

- 1 Hot-dip galvanised square tow bar
- 2 Chassis and frame hot-dip galvanised
- 3 13-pin plug
- 4 Load-securing options at the side perforations
- 5 Cable winch frame with cable winch and traction cable
- 6 Automatic jockey wheel, fitted in the centre
- 7 Tilting bridge mechanically tilted using shock absorbers.
- 8 Humbaur multifunctional lighting with reversing lights

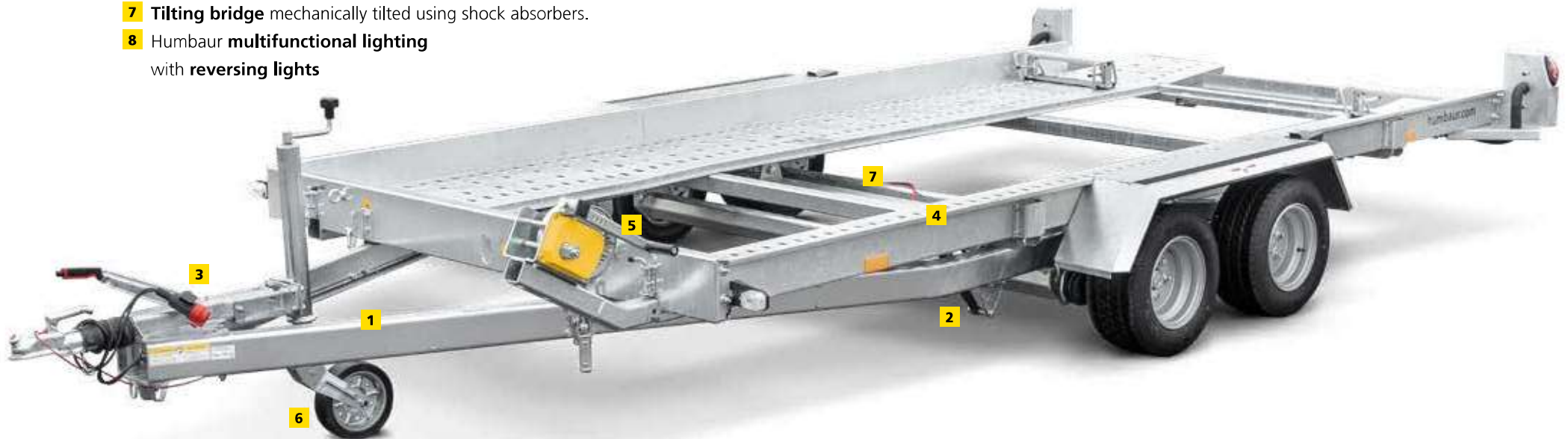

4000 Series

Model	HAK 204020	HAK 254020
Overall dimension in mm	5,965 x 2,495 x 930	5,965 x 2,495 x 930
Internal dimension in mm	4,060 x 2,005 x 130	4,060 x 2,005 x 130
Total permissible weight in kg	2,000	2,500
Load capacity in kg	1,360	1,812
Load height in mm	430	430
Tyres in inches	10	10
Ramp angle	9°	9°

Model	HAK 304020
Overall dimension in mm	5,965 x 2,495 x 930
Internal dimension in mm	4,060 x 2,005 x 130
Total permissible weight in kg	3,000
Load capacity in kg	2,312
Load height in mm	430
Tyres in inches	10
Ramp angle	9°

- 1 Perforated plate stand rails secure the load
- 2 Optimum anti-corrosion protection thanks to the entire frame and chassis being hot-dip galvanised
- 3 Cable winch frame with cable winch and traction cable fitted as standard
- 4 Humbaur multifunctional lighting with reversing lights

Subject to change without notice. All dimensions are approximate values and refer to the standard vehicle without accessories.



Vehicle transporter **HAK**



Accessories (optional):

- Spare wheel
- Wheel stop
- Loose wheel shock absorbers
- Fitted wheel shock absorbers
- 7-13-pin adapter
- Passenger vehicle lashing belt, 50 mm belt width, 2,500 mm
- 360 mm two-hand galvanised wheel stop (each piece)
- Double-acting cylinder for tilting the loading area



Vehicle transporter MTK (tandem tilting)

Extremely robust and long-lasting -
for true professional vehicle transportation

- 1 Bolted, **hot-dip galvanised chassis frame**
- 2 Welded, **hot-dip galvanised tilting bridge**
- 3 Tilting bridge **mechanically tilted** using pneumatic pressure absorbers.
- 4 **Steel loading ramps** can be pulled out from under the loading area
- 5 Cable winch **can be adjusted lengthways**
- 6 Perforated **standing area** to secure the load
- 7 6 pairs of **load-securing points** in the outer frame where length is 3,600 and 4,200, each with 400 kg of lashing capacity
- 8 8 pairs of **load-securing points** in the outer frame where length is 4,700, each with 400 kg of lashing capacity
- 9 **Tilting bridge mechanically locked in the lowered position**



Especially stable
thanks to transverse profiles
in the bridge

**Also available
as a single-axle
trailer!**



4000 Series

Model	MTK 254222	MTK 304222	MTK 354222
Overall dimension in mm	5,700 x 2,180 x 900	5,700 x 2,180 x 900	5,700 x 2,180 x 900
Internal dimension in mm	4,200 x 2,180	4,200 x 2,180	4,200 x 2,180
Total permissible weight in kg	2,500	3,000	3,500
Load capacity in kg	1,780	2,280	2,720
Load height in mm	650	650	650
Tyres in inches	13	13	13
Ramp angle	10°	10°	10°

Model	MTK 304722	MTK 354722
Overall dimension in mm	6,200 x 2,180 x 900	6,200 x 2,180 x 900
Internal dimension in mm	4,700 x 2,180	4,700 x 2,180
Total permissible weight in kg	3,000	3,500
Load capacity in kg	2,240	2,680
Load height in mm	650	650
Tyres in inches	13	13
Ramp angle	9°	9°

- 1 Especially stable thanks to double omega profiles in transverse direction on the bridge
- 2 Bridge with special pivot bearing
- 3 Hot-dip galvanised steel ramps can be retracted into the ramp shaft
- 4 Extreme stability thanks to a bolted, riveted and screw-retained bridge with solid bridge side members

Subject to change without notice. All dimensions are approximate values and refer to the standard vehicle without accessories.



Vehicle transporter MTK (tandem tilting)



Accessories (optional):

- Tarpaulin & frame load height 1,800 mm
- Tarpaulin & frame load height 2,000 mm
- Loose wheel shock absorbers
- Fitted wheel shock absorbers
- 350 mm aluminium side panels
- Wooden floor, stand rails removed
- Aluminium floor, stand rails removed
- Wooden floor between stand rails
- Double-acting cylinder for tilting the loading area
- 5-way transversely adjustable cable winch
- Electric cable winch, adjustable



Universal transporter MTK Allcomfort Tandem

Comfortable and easy loading and unloading of the trailer

- 1 Bolted, hot-dip galvanised chassis frame
- 2 Welded, hot-dip galvanised tilting bridge
- 3 Double-acting cylinder for tilting the loading area
- 4 Ramp gate, perforated with pneumatic spring support
- 5 Side panels made of anodised aluminium
- 6 Load-securing points in the outer frame with 400 kg of lashing capacity
- 7 Optional cable winch, 5-way transversely adjustable
- 8 Base plate 18 mm thick, weather-resistant

Also available
as a single-axle
trailer!



4000 Series

Model	MTKA 254222	MTKA 3042222	MTKA 354222
Overall dimension in mm	5,750 x 2,305 x 1,690	5,750 x 2,305 x 1,690	5,750 x 2,305 x 1,690
Internal dimension in mm	4,200 x 2,180 x 200	4,200 x 2,180 x 200	4,200 x 2,180 x 200
Total permissible weight in kg	2,500	3,000	3,500
Load capacity in kg	1,630	2,130	2,580
Load height in mm	650	650	650
Tyres in inches	13	13	13
Ramp angle	10°	10°	10°

Model	MTKA 304722	MTKA 354722
Overall dimension in mm	6,250 x 2,305 x 1,390	6,250 x 2,305 x 1,690
Internal dimension in mm	4,700 x 2,180 x 200	4,700 x 2,180 x 200
Total permissible weight in kg	3,000	3,500
Load capacity in kg	2,080	2,535
Load height in mm	650	650
Tyres in inches	13	13
Ramp angle	9°	9°

- 1 Especially stable thanks to double omega profiles in transverse direction on the bridge
- 2 Hot-dip galvanised end stanchions and clamp fasteners at the front
- 3 Optional with 5-way adjustable cable winch, traction cable and pulley

Subject to change without notice. All dimensions are approximate values and refer to the standard vehicle without accessories.



Universal transporter MTK Allcomfort Tandem



...Electric cable winch*

*Accessories (optional):

- Wheel stop for MTK
- Loose wheel shock absorbers
- Fitted wheel shock absorbers
- x 2 cantilever rods for tailgate, loose
- 350 mm-high aluminium side panels
- 5-way adjustable cable winch
- Adjustable electric cable winches
- Aluminium floor instead of wooden floor



Lowering trailer Senko

Our lowering all-rounder -
robust and durable

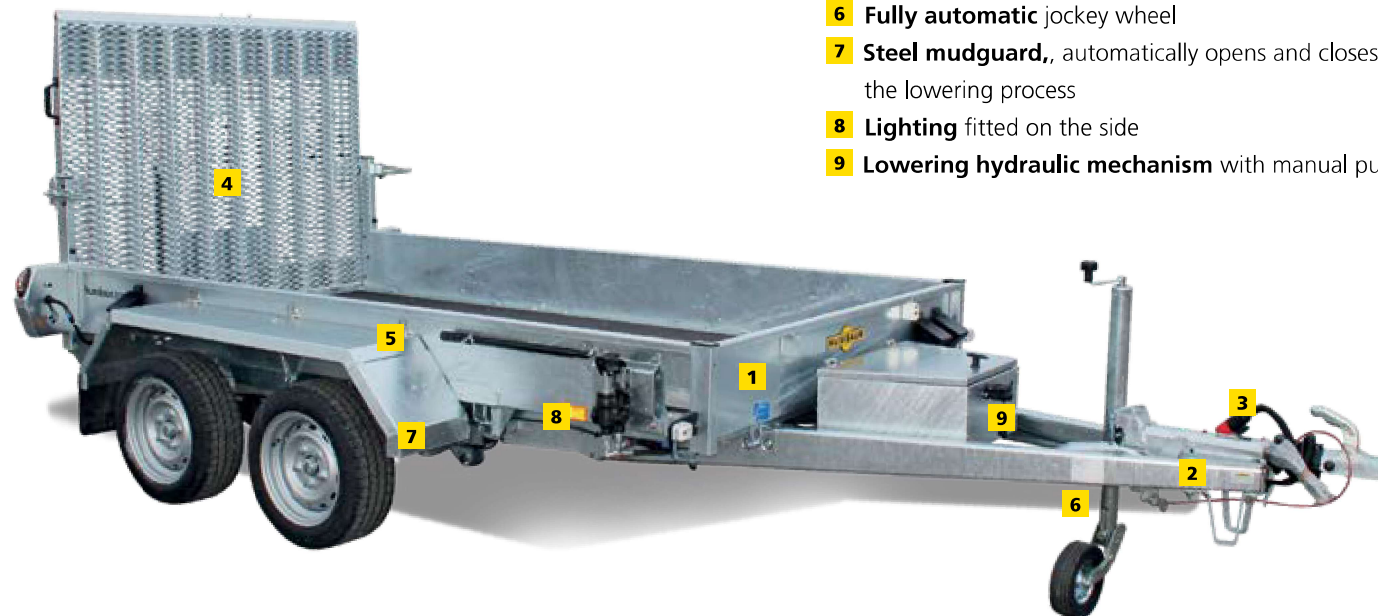

- 1 Welded side panel/frame construction** made of sheet steel, hot-dip **galvanised**
- 2 Bolted square tow bar**, hot-dip **galvanised**
- 3 13-pin plug** and reversing light
- 4 Hot-dip galvanised ramp gate with non-slip mesh surface** and **pneumatic spring support** (height approx. 1,240 mm, axle load tested to 2,500 kg)
- 5 Load-securing rings** fitted x 10 in the outer frame (5 pairs) for 3,000 mm and x 12 (6 pairs) for 3,750/3,990 mm body length, tensile force 1,000 kg for each load-securing ring
- 6 Fully automatic jockey wheel**
- 7 Steel mudguard**, automatically opens and closes during the lowering process
- 8 Lighting** fitted on the side
- 9 Lowering hydraulic mechanism** with manual pump

4000 Series

Model	Senko 253016	Senko 303016	Senko 353016	Senko 253718
Overall dimension in mm	4,750 x 2,230 x 1,740	4,750 x 2,230 x 1,740	4,680 x 2,230 x 1,740	5,500 x 2,480 x 1,740
Internal dimension in mm	3,000 x 1,600 x 270	3,000 x 1,600 x 270	3,000 x 1,600 x 270	3,750 x 1,850 x 270
Total permissible weight in kg	2,500	3,000	3,500	2,500
Load capacity in kg	1,775	2,260	2,740	1,655
Load height in mm	470	470	470	470
Tyres in inches	13	13	13	13
Ramp angle	7°	7°	7°	7°

Model	Senko 303718	Senko 353718	Senko 304019	Senko 354019
Overall dimension in mm	5,500 x 2,480 x 1,740	5,470 x 2,480 x 1,740	5,740 x 2,550 x 1,740	5,710 x 2,550 x 1,740
Internal dimension in mm	3,750 x 1,850 x 270	3,750 x 1,850 x 270	3,990 x 1,920 x 270	3,990 x 1,920 x 270
Total permissible weight in kg	3,000	3,500	3,000	3,500
Load capacity in kg	2,140	2,620	2,115	2,595
Load height in mm	470	470	470	470
Tyres in inches	13	13	13	13
Ramp angle	7°	7°	7°	7°

- 1 Tow bar box to protect the battery and the hydraulic lowering mechanism
- 2 Hot-dip galvanised ramp gate with non-slip mesh surface and pneumatic spring support

Subject to change without notice. All dimensions are approximate values and refer to the standard vehicle without accessories.



1



1



2

Lowering trailer Senko



Accessories (optional):

- Spare wheel
- Spare wheel bracket
- Side perforated rail
- Cable winch frame cpl. for lowering mechanism
- Cable winch with cable and pulley where there is an electric pump
- Alu Swiss ramp gate instead of steel ramp gate
- Hot-dip galvanised tow bar box
- H-frame
- Pump combined with emergency manual pump where there is a square two bar
- Tarpaulin & frame (1,800/2,000 mm) colour of your choice
- Aluminium chequer plate



Rexus all-poly trailer

Versatile transportation solutions
in a really cool design

- 1 **Chassis frame side member** hot-dip galvanised with wheel shock absorbers/suitable for 100 km/h
- 2 **13-pin plug**
- 3 **Base plate** 21 mm thick
- 4 **6 load-securing eyes** mounted on floor for **securing loads**
- 5 **Ramp gate** (optional with aluminium chequer plate) at the rear with **pneumatic spring support**, lockable, load capacity 1,300 kg, tested by Dekra.
- 6 **Doors** side front right with **three-point locking mechanism**, lockable
- 7 **Aluminium rims**
- 8 **Jockey wheel**
- 9 **Third brake light**



4000 Series

Model	REXUS
Overall dimension in mm	4,596 x 2,080 x 2,345
Internal dimension in mm	3,250 x 1,500 x 1,800
Total permissible weight in kg	2,000
Load capacity in kg	1,285
Load height in mm	460
Tyres in inches	15
Ramp angle	15°

Colours



Red Metallic



Orange Metallic



Yellow Metallic



Silver Metallic



Black Metallic



Blue Metallic



White

Please note that the colours shown may vary from the original colours.

Subject to change without notice. All dimensions are approximate values and refer to the standard vehicle without accessories.

- 1 Motorcycle stands as the ideal load support
- 2 Jacks (optional), design rear lights and decorative chrome hoops
- 3 Chassis frame side member for optimum longitudinal stability

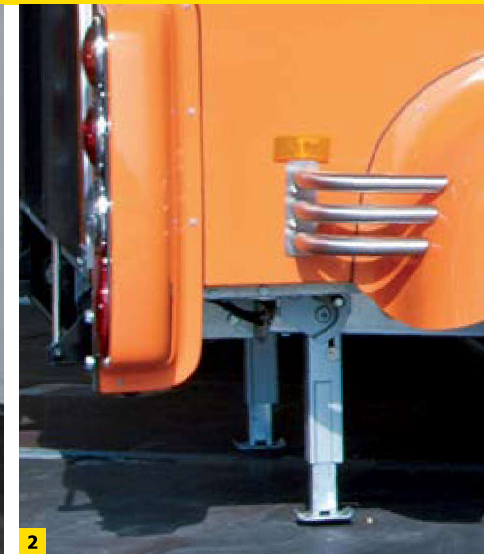

Rexus all-poly trailer



Accessories (optional):

- Spare wheel
- Motorcycle stand
- Locking bar for slotted tie-rail, interior width of 1,450-1,550 mm
- Locking bar for barred tie-rail for interior width 1,450-1,550 mm
- Fittings for load securing rail
- Motorcycle strap 25 mm
- Metal locking shoe with lock for overrun hitch up to 3.0 t
- AKS safety coupling, 2,000 kg
- Jacks
- Floating screed floor
- Spare wheel bracket
- Double hinge doors instead of ramp gate
- Rod lashing rails
- Slotted tie-rail
- Load securing rail left and right 2.2 m long
- Anti-theft Safety Compact
- Aluminium chequer plate
- 4 or 6 lashing rings recessed into wooden floor, tensile force of each 0.2 t or 0.4 t
- 4 folding rings
- Padlock for braked trailers up to 3,000 kg

Optional accessories – to meet your requirements

Body



Cantilever rods for tailgate, loose (2 piece)



Base plate coated with aluminium chequer plate



Double hinge doors instead of ramp gate

Lighting/electrics



7-13-pin adapter/13-7-pin adapter



Double-acting cylinder



Floating screed floor



Loading area, sealed throughout with phenolic resin-coated plywood



Reversing lights (only an option with 13-pin connector)



Cable winch with traction cable and pulley or cable winch frame



Standing rail with loop (supplied loose)

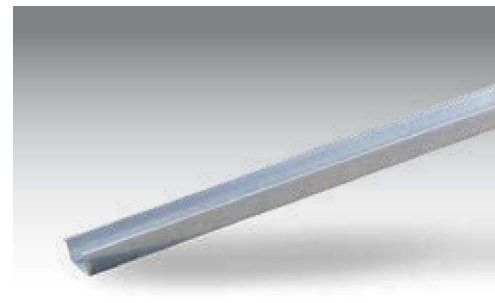

Additional loading ramp, loose (1 piece)

Tyres



Spare wheel

Chassis

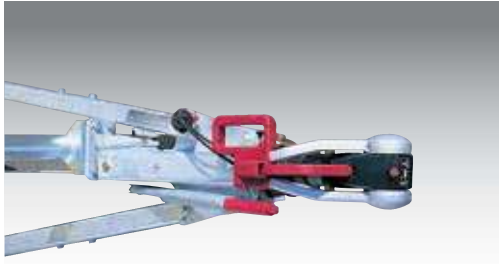

AKS safety clutch



Jacks with crank



Wheel shock absorbers (loose)



Prop stands (x 2)



Jockey wheel

Anti-theft device



Shackle lock for all braked trailers up to 3500 kg



Plug lock for unbraked trailers



Anti-theft Safety Compact



Metal locking shoe with lock

Optional accessories – to meet your requirements

Securing loads



Tie rings recessed into the wooden floors, assembled, tensile force 0.2 t each (4 piece) or 0.4 t (4 or 6 piece)



Fittings for load securing rail (x 4)



Folding rings (x 4)



Load securing rail



Motorcycle strap, 25 mm (x 4)



Motorcycle stands



Wheel lashing strap, 50 mm-wide

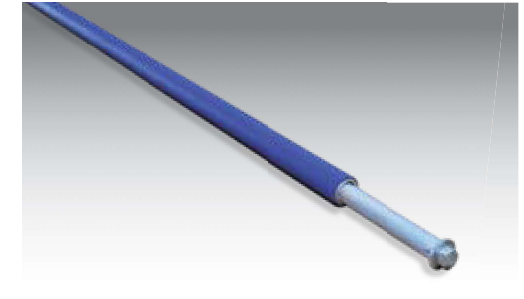

Wheel stop (locking bar)



Slotted tie-rail with locking bar



Barred tie-rail with locking bar

Tarpaulins



Tarpaulin & frame, load height 1,600 mm/1,800 mm/2,000 mm

Standard tarpaulin colours

Please note that the colours shown may vary from the original colours.

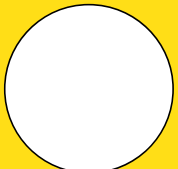

White/similar to RAL 9010

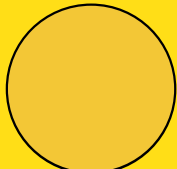

Medium Yellow/similar to RAL 1003

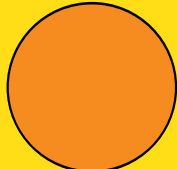

Orange/similar to RAL 2011



Red/similar to RAL 3002



Green/similar to RAL 6026



Blue/similar to RAL 5002

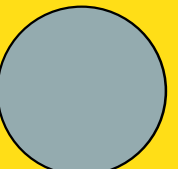

Grey/similar to RAL 7038

We are happy to create customised lettering on tarpaulins upon request!





"Humbaar Brand quality..."

...has been our motto since the company was established in 1957. With around 420 series-production models for the private and commercial sectors, Humbaar is now one of Europe's leading trailer manufacturers.

Innovative and experienced, with a presence throughout Europe and beyond. As an owner-managed, medium-sized family business, we know what our customers need and how they work. This is why we develop our products meticulously, manufacturing them with the greatest care and then putting them through their paces. Innovative ideas, cutting-edge manufacturing, a clear focus on quality and competent, comprehensive support are our strengths. Strengths that we employ to serve our customers.

*Ulrich Humbaar
Proprietor, Director/CEO*





MAKES IT HAPPEN

Competence in trailers

▶ Take a look at our product range...

We offer a large variety of trailer models. Have a look at our brochures for our **single/tandem-axle trailers**, our **vehicle, animal** and **universal transporters**, **heavy-duty trailers** and **freight trailers**. We will gladly customise a trailer to meet your needs. Please contact us to discuss your requirements.



Your Humbaур-Dealer

Safety information: The trailer may only be used with express approval by all road traffic professional association and load securing regulations. We assume no responsibility for damage to other persons or possessions. Subject to change without notice. All dimensions are approximate values and refer to the standard vehicle without accessories. Printed in Germany. Reprinting prohibited - Illustrations are similar, some trailers and accessories show special equipment. - Order No. 109-000100 - As at: 07/19.



3000/3500 Series

Humbaур GmbH / Mercedesring 1 / 86368 Gersthofen / Germany / Tel. +49 821 24929-0 / info@humbaур.com /umbaур.com